

# SERIE 300

## PONTE DIFFERENZIALE STERZANTE CON RIDUTTORI FINALI DEL TIPO EPICICLOIDALE

Steering differential axle with epicycloid type final reduction units  
 Pont différentiel directeur avec réduct. finals du type epicycloidal  
 Differentiallenkachse mit endplanetenuntersetzungsgetrieben

# EME P-304-F.i.-V

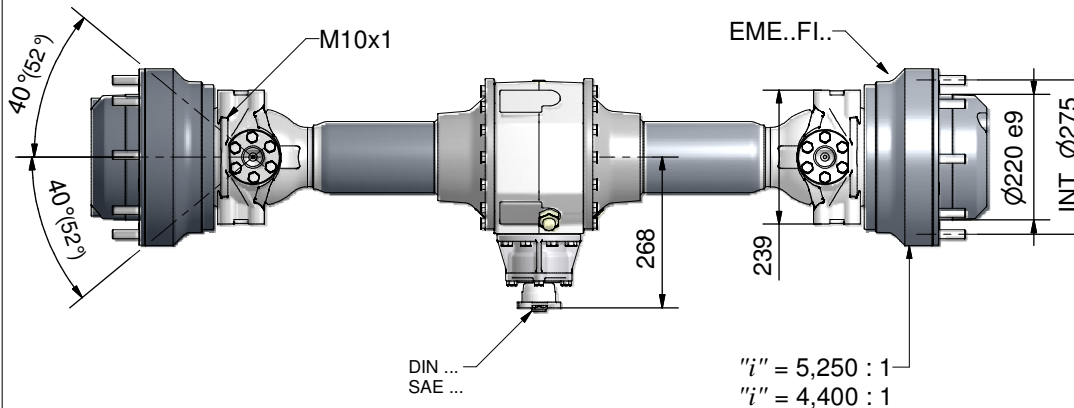
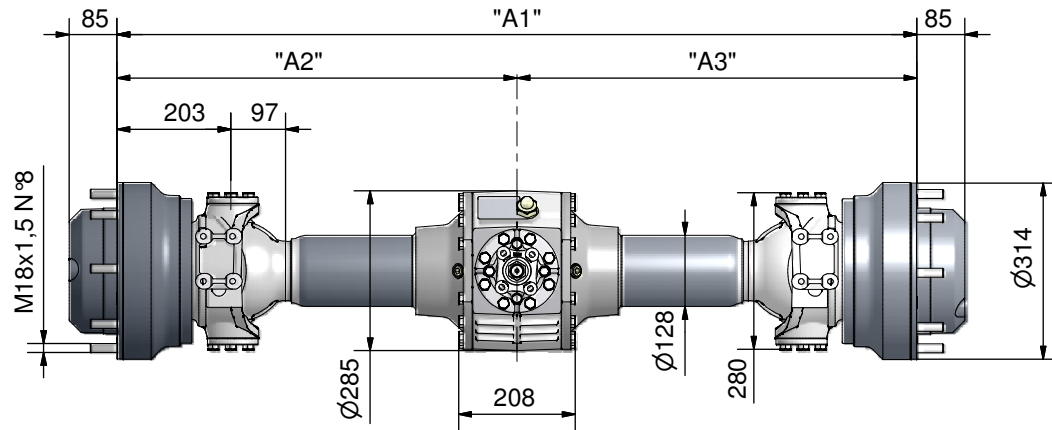

### DATI TECNICI-SPECIFICATIONS-DONNEES TECHIQUES-TECHNISCHE DATEN

PORTATA DINAMICA DYNAMIC CAPACITY PORTEE DYNAMIQUE DYNAMISCHE TRAGKRAFT	da N (kg) <b>8000</b>	COPPIA MAX. ALL'USCITA MAX OUTPUT TORQUE COUPLE MAXI A LA SORTIE MAX ABTRIEBSDREHMOMEN	da Nm (kgm) <b>2800</b>
--	--------------------------	---	----------------------------

PORTATA STATICA STATIC CAPACITY PORTEE STATIQUE STATISCHE TRAGKRAFT	da N (kg) <b>16000</b>
--	---------------------------

RAPPORTI TOTALI TOTAL CAPACITY RAPPORTS TOTAUX GANZE UNTERSATZUNGEN	"i" <b>16,333 : 1</b>	<b>19,250 : 1</b>
	"i" <b>22,968 : 1</b>	<b>28,218 : 1</b>

CARREGGIATA - TRACK VOIE - SPURWEITE	(mm)	"A1"
---	------	------

FRENATURA IDRAULICA MULTIDISCO IMMERSI IN OLIO ALLE RUOTE  
 MULTIDISC HYDRAULIC BRAKING IN OIL BATHED TO WHEELS  
 FREINAGE HYDRAULIQUE MULTIDISQUE PLONGES DANS L'HUILE AUX ROUES  
 HYDRAULISCHE MEHRSCHEIBE BREMSUNG IM OL GETAUCHT AN RADERN

EME..FI..  
 (Pag. 010-050)

### OPTIONAL

CARREGGIATA COMPOSTA COMPOUND TRACK VOIE COMPOSEE ZUSAMMENSETZTE SPURWEITE	(mm)	"A1"="A2"+"A3"
---	------	----------------

FISSAGGIO AL TELAIO OSCILLANTE  
 FIXING TO THE OSCILLATING FRAME  
 FIXATION AU CHASSIS OSCILLANT  
 BEFESTIGUNG AM SCHWINGENDEN RAHMEN

EME ..BASC..

BLOCCAGGIO DIFFERENZIALE - DIFFERENTIAL LOCK  
 BLOCAGE DU DIFFERENTIEL - DIFFERENTIALSPERRE

EME..LS..(LIMITED SLIP 40%) - EME NO SPIN  
 EME ..BL180 (100%)

STAZIONAMENTO MULTIDISCHI A COMANDO NEGATIVO  
 MULTIDISC PARKING WITH NEGATIVE CONTROL  
 STATIONNEMENT MULTIDISQUES A' COMMANDE NEGATIVE  
 MEHRSCHEIBEN PARKIERBREMSUNG MIT NEGATIVSTEUERUNG

EME...F.N

SENZA FRENI - WITHOUT BRAKES - SANS FREINS - OHNE BREMSEN

EME...S.F.

DISINNESTO - RELEASE - DEBRANCHEMENT - ABSCHALTUNG

EME...DR 182

COMANDO STERZATURA MEDIANTE CILINDRO IDRAULICO INTEGRALE  
 STEERING CONTROL THROUGH COMPLETE HYDRAULIC CYLINDER  
 COMMANDE BRAQUAGE PAR CYLINDRE HYDRAULIQUE COMPLET  
 LENKUNG DURCH KOMPLETTEN HYDRAULISCHEN ZYLINDER

EME...SI5  
 (Pag. 010-090)

