

# SERIE 170

## PONTE DIFFERENZIALE STERZANTE CON RIDUTTORI FINALI DEL TIPO EPICICLOIDALE

Steering differential axle with epicycloid type final reduction units  
 Pont différentiel directeur avec réduct. finals du type epicycloidal  
 Differentiallenkachse mit endplanetenuntersetzungsgetrieben

# EME P-174-F.i.-V

### DATI TECNICI-SPECIFICATIONS-DONNEES TECHIQUES-TECHNISCHE DATEN

PORTATA DINAMICA DYNAMIC CAPACITY PORTEE DYNAMIQUE DYNAMISCHE TRAGKRAFT	da N (kg) <b>5500</b>	COPPIA MAX. ALL'USCITA MAX OUTPUT TORQUE COUPLE MAXI A LA SORTIE MAX ABTRIEBSDREHMOMEN	da Nm (kgm) <b>1500</b>
--	--------------------------	---	----------------------------

PORTATA STATICA STATIC CAPACITY PORTEE STATIQUE STATISCHE TRAGKRAFT	da N (kg) <b>11000</b>
--	---------------------------

RAPPORTI TOTALI TOTAL CAPACITY RAPPORTS TOTAUX GANZE UNTERSETZUNGEN	"i" <b>13,933 : 1</b>	<b>16,500 : 1</b>
	"i" <b>19,687 : 1</b>	<b>24,187 : 1</b>

CARREGGIATA - TRACK VOIE - SPURWEITE	(mm)	"A1"="A2"+"A3"
---	------	----------------

FRENATURA IDRAULICA MULTIDISCO IMMERSI IN OLIO ALLE RUOTE  
 MULTIDISC HYDRAULIC BRAKING IN OIL BATHED TO WHEELS  
 FREINAGE HYDRAULIQUE MULTIDISQUE PLONGES DANS L'HUILE AUX ROUES  
 HYDRAULISCHE MEHRSCHEIBE BREMSUNG IM OL GETAUCHT AN RADER

EME..F.I..

### OPTIONAL

CARREGGIATA COMPOSTA COMPOUND TRACK VOIE COMPOSEE ZUSAMMENGESETZTE SPURWEITE	(mm)	"A1"
---	------	------

FISSAGGIO AL TELAIO OSCILLANTE FIXING TO THE OSCILLATING FRAME FIXATION AU CHASSIS OSCILLANT BEFESTIGUNG AM SCHWINGENDEN RAHMEN		EME ..BASC..
--	--	--------------

BLOCCAGGIO DIFFERENZIALE - DIFFERENTIAL LOCK BLOCAGE DU DIFFERENTIEL - DIFFERENTIALSPERRE		EME..LS..(LIMITED SLIP 40%) - EME NO SPIN EME ..BL180 (100%)
--	--	---

STAZIONAMENTO MULTIDISCHI A COMANDO NEGATIVO MULTIDISC PARKING WITH NEGATIVE CONTROL STATIONNEMENT MULTIDISQUES A' COMMANDE NEGATIVE MEHRSCHEIBEN PARKIERBREMSUNG MIT NEGATIVSTEUERUNG		(20 bar) EME...F.N
---	--	--------------------

SENZA FRENI - WITHOUT BRAKES - SANS FREINS - OHNE BREMSEN		EME...S.F.
---	--	------------

DISINNESTO - RELEASE - DEBRANCHEMENT - ABSCHALTUNG		EME...DR 182
--	--	--------------

COMANDO STERZATURA MEDIANTE CILINDRO IDRAULICO INTEGRALE STEERING CONTROL THROUGH COMPLETE HYDRAULIC CYLINDER COMMANDE BRAQUAGE PAR CYLINDRE HYDRAULIQUE COMPLET LENKUNG DURCH KOMPLETTEN HYDRAULISCHEN ZYLINDER		EME...SI4
---	--	-----------

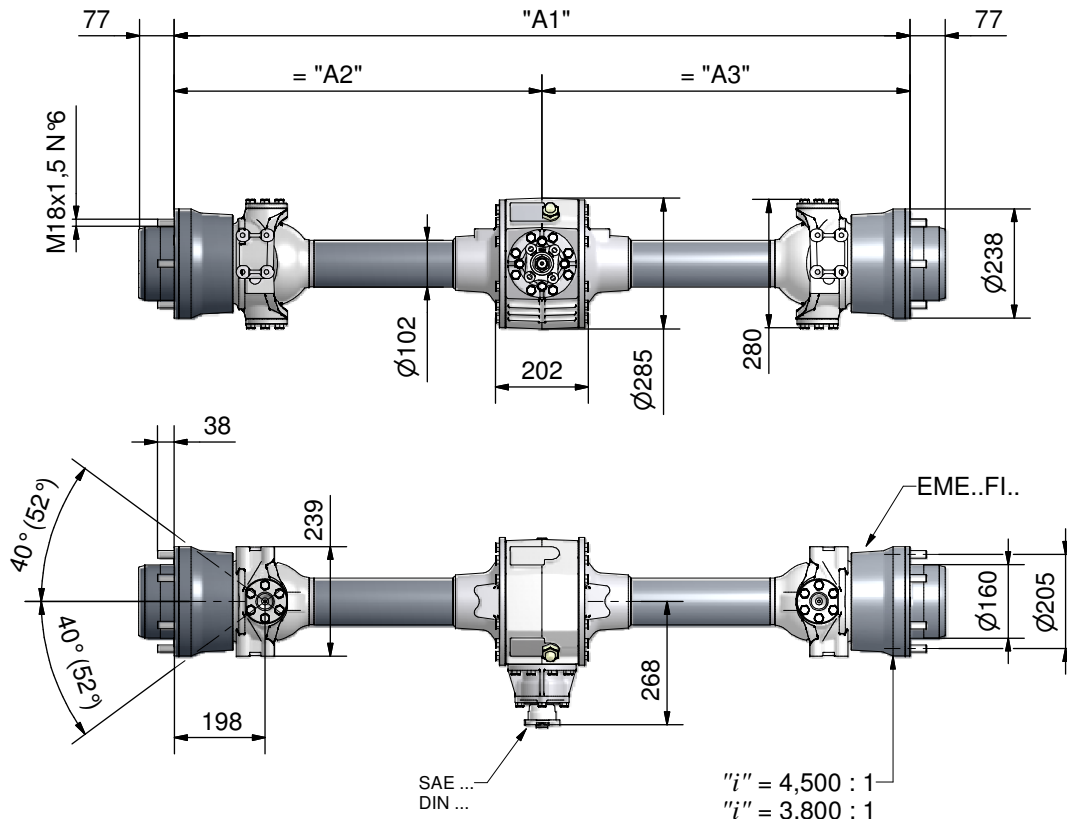

PATENT n° MO97U000038

THE SPECIFIED DATA ARE FOR PRODUCT DESCRIPTION PURPOSE ONLY AND MUST NOT BE INTERPRETED AS WARRANTED CHARACTERISTIC IN LEGAL SENSE

PAG. N° 006-290

SERIE 170