

# SERIE 650

## RIDUTTORE RIPARTITORE PER DOPPIA TRAZIONE REDUCTION UNIT DISTRIBUTOR FOR 4 WHEELS DRIVE REDUCTEUR REPARTITEUR POUR 4 ROUES MOTRICES UNTERSETZUNGS VERTEILERGETRIEBE FÜR ALLRADANTRIEB

## EME R 650-2 iDR-UV2

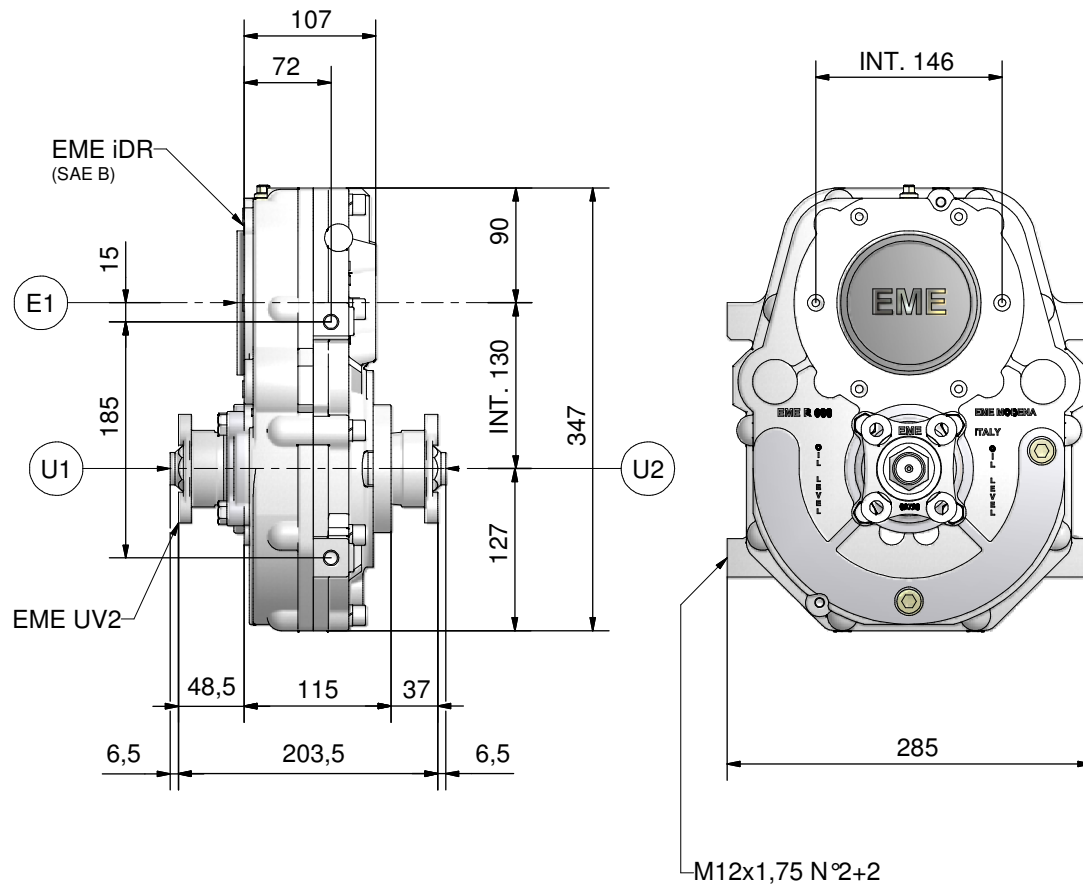

### DATI TECNICI-SPECIFICATIONS-DONNEES TECHIQUES-TECHNISCHE DATEN

COPPIA MAX. IN ENTRATA - MAX INPUT TORQUE COUPLE MAXI A L'ENTREE - MAX ANTRIEBSDREHMOMENT	da Nm (kgm)	55
COPPIA MAX. IN USCITA - MAX. OUTPUT TORQUE COUPLE MAXI A LA SORTIE - MAX. ABTRIEBSDREHMOMENT	da Nm (kgm)	180
REGIME MAX. IN ENTRATA - MAX INPUT REVERS PER MINUTE REGIME MAXI A L'ENTREE - MAX ANTRIEBSDREHZAHL	giri/min	5000

### PREDISPOSIZIONI - PREDISPOSITIONS - DISPOSITIONS - VOREINSTELLUNGEN

MOTORE IDROSTATICO - HYDROSTATIC ENGINE MOTEUR HYDROSTATIQUE - HYDROSTATISCHER MOTOR	EME ..iDR (SAE B)	(E1)
FLANGIA AL GIUNTO - FLANGE TO THE JOINT Pag.010-015 BRIDE AU JOINT - KUPPLUNGSFLANSCH	EME ..UV 2 (SAE 100/2)	(U1 U2)
FLANGIA AL PONTE - FLANGE TO THE AXLE BRIDAGE A' L'ESSIEU - ACHSFLANSCHEN	(Pag...004-045)	

RAPPORTI - RATIOS - RAPPORTS - UNTERSETZUNGEN "i"		
5,833 : 1	4,453 : 1	3,315 : 1

