

# SERIE 500

## RIDUTTORE RIPARTITORE SINCRONIZZATO A 2 VEL. CON DIFFERENZIALE IN USCITA

2 SPEEDS SYNCHRO-MESH TRANSFER REDUCER WITH DIFFERENTIAL IN OUTPUT  
 REDUCTEUR REPARTITEUR SYNCHRONISE A 2 VITESSES AVEC DIFFERENTIEL A LA SORTIE  
 2 GANG SYNCHRONGETRIEBE / VERTEILERGETRIEBE MIT DIFFERENTIAL AM AUSGANG

**EME R 500-2 iDR-UV2D-R-BL500-SINC**

EME ..UV2D-R-BL 500

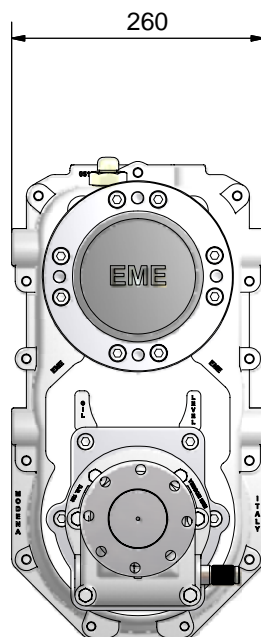
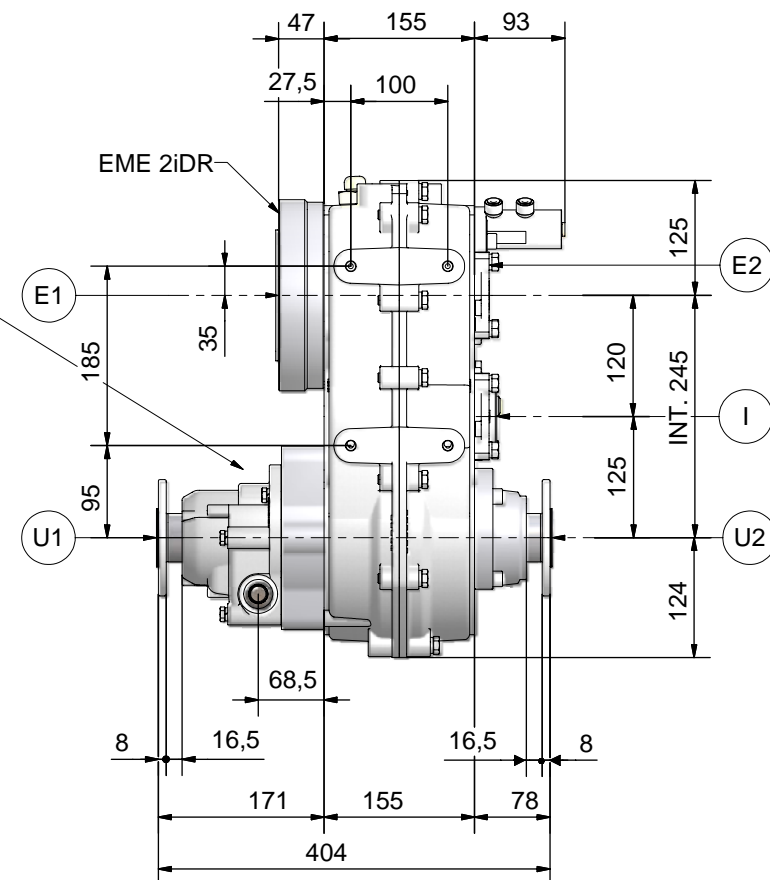

### DATI TECNICI-SPECIFICATIONS-DONNEES TECHIQUES-TECHNISCHE DATEN

COPPIA MAX. IN ENTRATA - MAX INPUT TORQUE  
 COUPLE MAXI A L'ENTREE - MAX ANTRIEBSDREHMOMENT da Nm (kgm) 90

COPPIA MAX. IN USCITA - MAX. OUTPUT TORQUE  
 COUPLE MAXI A LA SORTIE - MAX. ABTRIEBSDREHMOMENT da Nm (kgm) 330

REGIME MAX. IN ENTRATA - MAX INPUT REVERS PER MINUTE  
 REGIME MAXI A L'ENTREE - MAX ANTRIEBSDREHZAHL giri/min 6000

### PREDISPOSIZIONI - PREDISPOSITIONS - DISPOSITIONS - VOREINSTELLUNGEN

MOTORE IDROSTATICO - HYDROSTATIC ENGINE  
 MOTEUR HYDROSTATIQUE - HYDROSTATISCHER MOTOR EME ..2iDR (SAE B) (E1)

DIFFERENZIALE INTERNO - INSIDE DIFFERENTIAL  
 DIFFERENTIEL INTERIEUR - INNENDIFFERENTIAL EME ..UV 2 D - R

BLOCCAGGIO DIFFERENZIALE - DIFFERENTIAL LOCK  
 BLOCAGE DU DIFFERENTIEL - DIFFERENTIALSPERRE EME ..BL 500 (DIN 120)

FLANGIA AL GIUNTO - FLANGE TO THE JOINT  
 BRIDE AU JOINT - KUPPLUNGSFLANSCH EME ..UV 2 (DIN 120) (U2)

CONTACHILOMETRI - ODOMETER  
 COMPTEUR KILOMETRIQUE - KILOMETERZAHLER EME ..C.C.I. (I)

SENSORE - SENSOR  
 CAPTEUR - SENSOR EME ..S.P.

### OPTIONAL

FLANGIATURA AL PONTE - FLANGING TO THE AXLE  
 BRIDAGE A L'ESSIEU - ACHSFLANSCHEN

(Pag...004-045)

RAPPORTI - RATIOS - RAPPORTS - UNTERSETZUNGEN "i"	
"V"	"L"
1,2285 : 1	3,7424 : 1
1,4857 : 1	4,5261 : 1
1,9487 : 1	5,9368 : 1
2,6432 : 1	8,0525 : 1

