

# SERIE 500

## RIDUTTORE RIPARTITORE A 2 VELOCITA' 2 SPEEDS DISTRIBUTOR REDUCTION UNIT REDUCTEUR REPARTITEUR A 2 VITESSES 2 GANG UNTERSETZUNGS VERTEILERGETRIEBE

## EME R 500-2 iDR-UV2

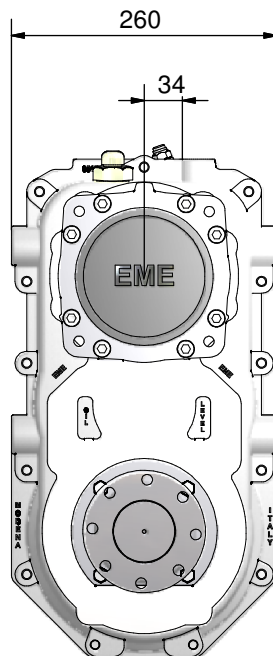
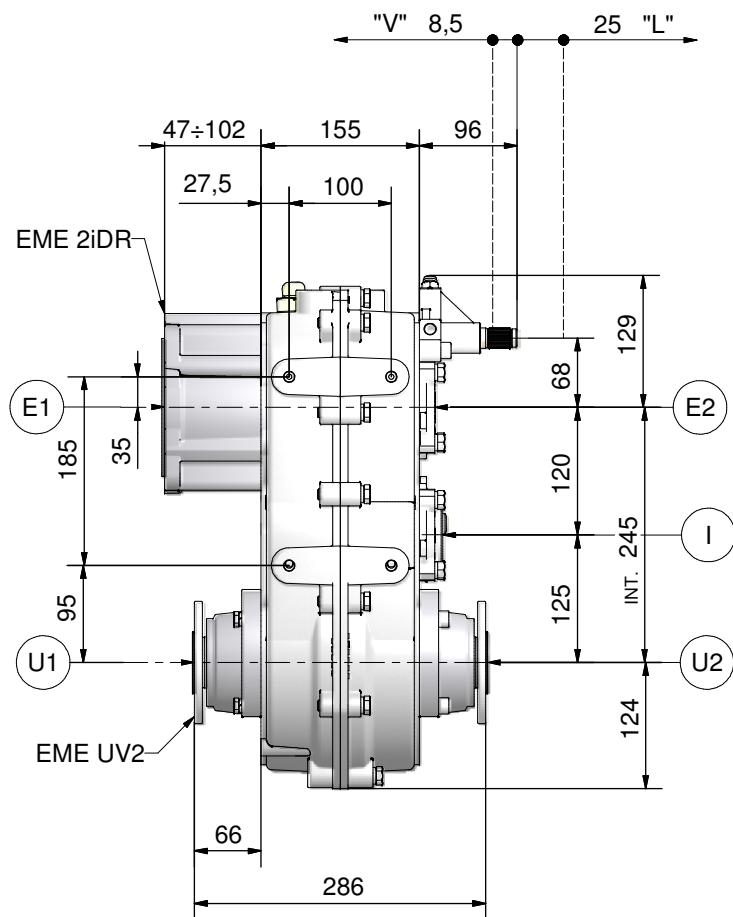

### DATI TECNICI-SPECIFICATIONS-DONNEES TECHIQUES-TECHNISCHE DATEN

COPPIA MAX. IN ENTRATA - MAX INPUT TORQUE  
 COUPLE MAXI A L'ENTREE - MAX ANTRIEBSDREHMOMENT da Nm (kgm) 90

COPPIA MAX. IN USCITA - MAX. OUTPUT TORQUE  
 COUPLE MAXI A LA SORTIE - MAX. ABTRIEBSDREHMOMENT da Nm (kgm) 330

REGIME MAX. IN ENTRATA - MAX INPUT REVERS PER MINUTE  
 REGIME MAXI A L'ENTREE - MAX ANTRIEBSDREHZAHL giri/min 6000

### PREDISPOSIZIONI - PREDISPOSITIONS - DISPOSITIONS - VOREINSTELLUNGEN

MOTORE IDROSTATICO - HYDROSTATIC ENGINE  
 MOTEUR HYDROSTATIQUE - HYDROSTATISCHER MOTOR EME ..2iDR (SAE B) (E1)

FLANGIA AL GIUNTO - FLANGE TO THE JOINT  
 BRIDE AU JOINT - KUPPLUNGSFLANSCH EME ..UV 2 (DIN 120) (U1 U2)

CONTACHILOMETRI - ODOMETER  
 COMPTEUR KILOMETRIQUE - KILOMETERZAHLER EME ..C.C.I. (I)

SENSORE - SENSOR  
 CAPTEUR - SENSOR EME ..S.P.

### OPTIONAL

FLANGIA AL GIUNTO DISINSERIBILE - FLANGE TO THE DISCONNECTABLE JOINT  
 BRIDAGE AU JOINT DEBRAYABLE - FLANSCH AM ABSCHALTBAAREN GELENK EME ..UV2-DR182

FLANGIATURA AL PONTE - FLANGING TO THE AXLE  
 BRIDAGE A L'ESSIEU - ACHSFLANSCHEN (Pag...004-045)

RAPPORTI - RATIOS - RAPPORTS - UNTERSETZUNGEN "i"	
"V"	"L"
1,2285 : 1	3,7424 : 1
1,4857 : 1	4,5261 : 1
1,9487 : 1	5,9368 : 1
2,6432 : 1	8,0525 : 1

